

**Product introduction**

**Description**

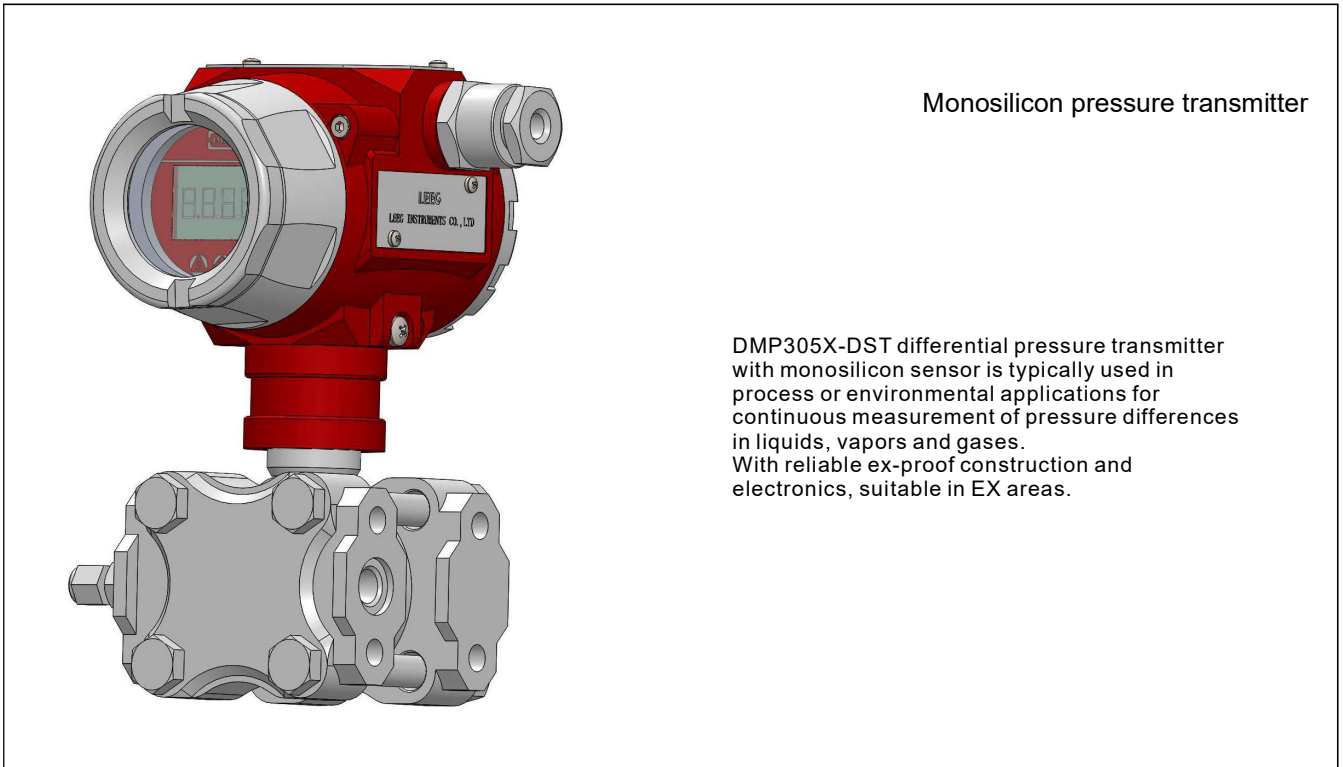

**Main parameters**

Pressure types	Differential pressure
Measuring range	20kPa-10MPa, Please refer to the ordering information chapter
Output signal	4-20mA, 4-20mA+HART, Modbus-RTU/RS485 customer
Reference accuracy	±0.15%URL, optional ±0.1%URL

**Measuring medium**

Liquid, gas, or steam flow as well as liquid level, density and pressure

**Approvals**



Technical specifications

Measuring range and limit

Nominal value	Smallest calibratable span	Lower range limit (LRL)	Upper range limit (URL)	Static pressure limit
40kPa	20kPa	0kPa	40kPa	16MPa
250kPa	50kPa	0kPa	250kPa	16MPa
1MPa	200kPa	0kPa	1MPa	16MPa
10MPa	1MPa	0kPa	10MPa	20MPa

Adjust requirements: lower range value (LRV) and upper range value (URV) can be adjusted within the scope of the upper and lower range limit,  $\text{span} = |\text{URV} - \text{LRV}| \geq \text{smallest calibratable span}$

Standard specifications and reference conditions

Test standard: GB/T28474 / IEC60770; zero based-calibration span, linear output, silicone oil filling, 316L stainless steel isolation diaphragm.

Power supply effects

When power supply voltage is within 10.5/16.5-55VDC, zero and span change should not more than  $\pm 0.005\% \text{ URL/V}$

Performance specifications

The overall performance including but not limited to **【Reference accuracy】**, **【Environment temperature effects】** and other comprehensive error

Typical accuracy:  $\pm 0.15\% \text{ URL}$

Stability:  $\pm 0.2\% \text{ URL/5 years}$

Mounting position effects

Install error less than 400Pa, which can be corrected by PV=0 reset.

Reference accuracy

Including linearity, hysteresis and repeatability. calibration temperature:  $20^{\circ}\text{C} \pm 5^{\circ}\text{C}$

Linear output accuracy	$\text{TD} \leq 10$ (note 1)	$\pm 0.15\% \text{ SPAN}$ (note 2)	Nominal value 40kPa, 250kPa 1MPa, 10MPa
	$10 < \text{TD} \leq 20$	$\pm 0.015 \text{ TD}\% \text{ SPAN}$	

Square root output accuracy is 1.5 times linear output accuracy

Note 1: TD is Turn down,  $\text{TD} = \text{URL} / |\text{URV} - \text{LRV}|$

Note 2:  $\text{SPAN} = |\text{URV} - \text{LRV}|$

Vibration effects

According to IEC61298-3,  $< 0.1\% \text{ URL}$

Output signal

Two wire 4-20 mA output with digital communications, linear or square root output programmable, HART protocol is superimposed on the 4-20mA signal.

Ambient temperature effects

Per $10^{\circ}\text{C}$ change within the limits $-20$ - $80^{\circ}\text{C}$	$\pm (0.1 + 0.015 \text{ TD})\% \text{ SPAN}$
--	---

Technical specifications

Damping time

Total damping time constant: equal to the sum of damping time of amplifier and sensor capsule
Damping time of amplifier : 0-100S adjustable
Damping time of sensor capsule (isolation sensor diaphragm and silicon filling oil)≤0.2S
Startup after power off: ≤6S
Normal services after data recovery: ≤31S
Response time: ≤150ms

Weight

Net weight: about 4 kg ( without mounting bracket and process connection adaptor )
--

Power supply

Item	Operating conditions
Standard/flame proof	10.5-55VDC
HART protocol	16.5-55VDC, communication load resistance 250Ω
Modbus-RTU/RS485	5-32VDC
Load resistance	0-2119Ω for operation, 250-600Ω for HART protocol
Transmission distance	<1000 meters
Power consumption	≤500mW@24VDC, 20.8mA

Power supply and load requirements

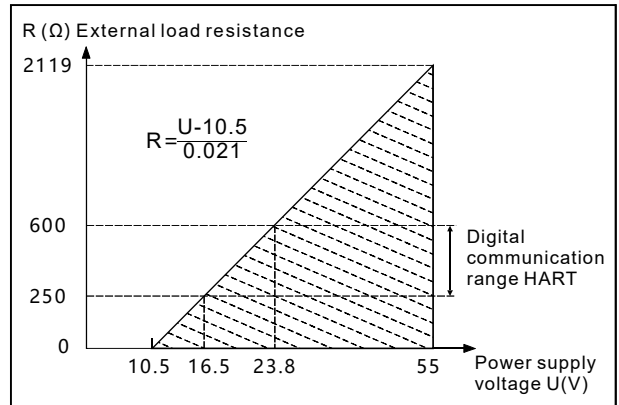

Environment condition

Items	Operational condition	
Working temperature	-40-85°C, integrated LCD display : -20-70°C	
Storage temperature	-40-110°C, integrated LCD display : -40-85°C	
Media temperature	Silicone oil filling: -40-120°C	
	Inert oil filling: -40-85°C	
Working humidity	5-100%RH@40°C	
Protection class	IP66/IP67	
Dangerous condition	NEPSI	ExiaIICT4(GYB16.1962X)* ExdIICT6(GYB16.1254X)*
	ATEX	Ex db IIC T6 Gb, Ex tb IIIC T80°C Db(CML 19ATEX1078X)* Ex ia IIC T4 Ga(CML 19ATEX1078)*
	IECEX	Ex db IIC T6 Gb, Ex tb IIIC T80°C Db(IECEX NEP 18.0008X)* Ex ia IIC T4 Ga(IECEX NEP 18.0008X)*
	CSA	Class I, Division 1, Group A, B, C and D T6 Class II, Division 1 Group E, F and G T80°C Class III (No.: 80020805)*

\*Please consult engineers for details

Disclaimer: all the data used in the product description is not legally binding. Relevant technical details may be changed due to further improve

EMC environment

NO.	Test items	Basic standards	Test conditions	Performance level
1	Radiated interference	GB/T 9254/CISPR22	30MHz-1000MHz	OK
2	Conducted interference (DC power port)	GB/T 9254/CISPR22	0.15MHz-30MHz	OK
3	Electrostatic discharge immunity test (ESD)	GB/T 17626.2/IEC61000-4-2	4kV(Contact ),8kV(Air)	B(Note2)
4	Immunity to radio frequency EM-fields	GB/T 17626.3/IEC61000-4-3	10V/m(80MHz-1GHz)	A(Note1)
5	Power frequency magnetic field Immunity test	GB/T 17626.8/IEC61000-4-8	30A/m	A(Note1)
6	Electrical fast transient / Burst Immunity test	GB/T 17626.4/IEC61000-4-4	2kV(5/50ns,100kHz)	B(Note2)
7	Surge immunity requirements	GB/T 17626.5/IEC61000-4-5	1kV(Line to line) 2kV(Line to ground) (1.2us/50us)	B(Note2)
8	Immunity to conducted disturbances induced by radio frequency fields	GB/T 17626.6/IEC61000-4-6	3V(150kHz-80MHz)	A(Note1)

(Note 1)Performance level A: The performance within the limits of normal technical specifications.

(Note 2)Performance level B: Temporary reduction or loss of functionality or performance, it can restore itself. The actual operating conditions, storage and data will not be changed.

Menu function

Specific menu

Transmission module type

Output signal	Local control	Remote control
4-20mA+HART	LCD/3 buttons on body	HART
4-20mA	LCD/3 buttons on body	-

LCD display unit

Display mode	Details
PV	Process variable shows on main screen, percentage and progress bar shows on secondary screen
mA	Current shows on main screen, percentage and progress bar shows on secondary screen
%	Percentage shows on main screen, percentage and progress bar shows on secondary screen

Unit

Unit	Definition
kPa	Kilopascal
MPa	Megapascals
bar	Bar
psi	Pounds per square inch
mmHg	Millimetre(s) of mercury@0°C
mmH2O	Millimeter of water@4°C
mH2O	Meter of water@4°C
inH2O	Inches of water@4°C
ftH2O	Feet of water@4°C
inHg	Inches of mercury@0°C
mHg	Meter mercury column@0°C
TORR	Torr
mbar	Millibar
g/cm2	Gram per square centimeter
kg/cm2	Kilogram per square centimeter
Pa	PA
ATM	Standard atmospheric pressure
mm	Millimeter(Note1)
m	Meter(Note1)

Note1: length unit need mark medium density

Measuring menu set

Mark	State
URV	Upper range value, 20mA
LRV	Lower range value, 4mA

Damping time

Units	Setting range
S	0-100

Analog output type

Parameters	Output type
mA LINER	Linearity
mA $\sqrt{\quad}$	Square root

Alarm signal

Parameters	Alarm signal
ALARM NO	None
ALARM H	20.8mA
ALARM L	3.8mA

Fix output

Parameters	Fix output value
FIX/C NO	None
3.8000	3.8000mA
4.0000	4.0000mA
8.0000	8.0000mA
12.000	12.000mA
16.000	16.000mA
20.000	20.000mA
20.800	20.800mA

Quick menu

Parameter	Instruction
Zero adjustment	4mA re-range with pressure
Span adjustment	20mA re-range with pressure
Restore factory setting	Restore backup data when error

Product selection instruction

Sensor select instruction

Code	Nominal value	Description
S403A	40kPa	Range 0-40kPa, smallest calibratable span 20kPa
S254A	250kPa	Range 0-250kPa, smallest calibratable span 50kPa
S105A	1MPa	Range 0-1000kPa, smallest calibratable span 200kPa
S106A	10MPa	Range 0-10MPa, smallest calibratable span 1MPa

Code	Position	Instruction
S	Diaphragm material	SUS316L
H		Hastelloy C
S	Fluid filling	Silicon oil, temperature resistance: -45-205°C
D		Inert oil, temperature resistance: -45-160°C
P	Sensor seal	O-ring, PTFE, temperature resistance: -100-280°C

Diaphragm(S/H)

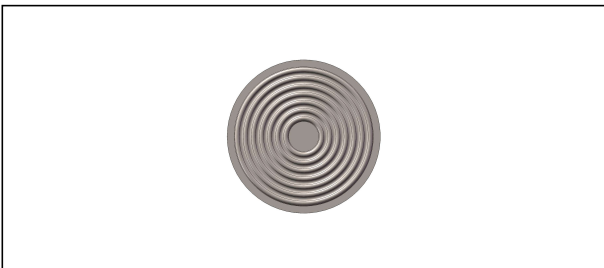

Seal(S)

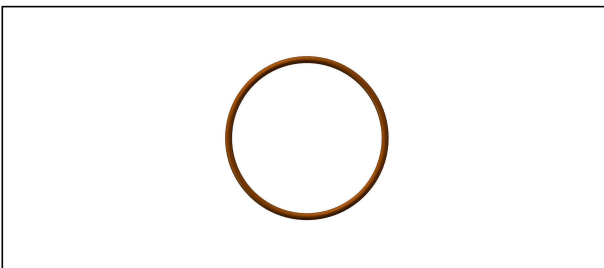

Electrical connection select instruction

Code	Item	Description
T1	Electrical connection	Aluminum-alloy terminal, 2 cable entry M20*1.5(F), red body, white cover
R1	Cable entry protector	Waterproof connector M20X1.5 one side, blind plug another side, PVC material, 6-8mm diameter cable only, IP67
R2		Flame proof, 1/2 NPT(F) one side, blind plug another side, stainless steel material, 6-8mm diameter cable only, IP67
R3		Flame proof, M20X1.5(F) one side, blind plug another side, stainless steel material, 6-8mm diameter cable only, IP67

Housing (T1)

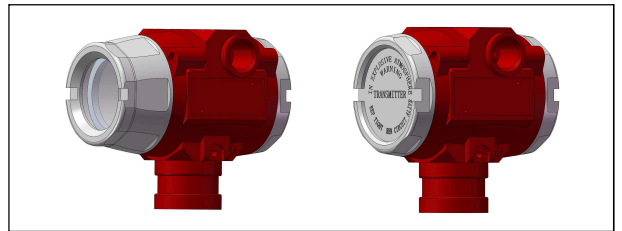

Standard cable entry protective adaptor(R1)

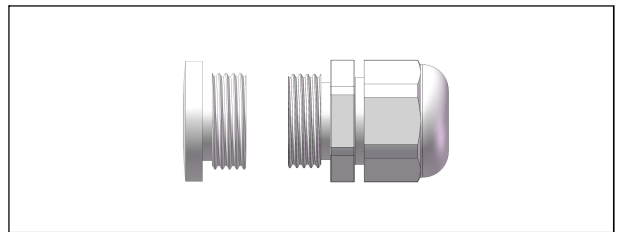

Flame proof cable entry protective adaptor(R2/R3)

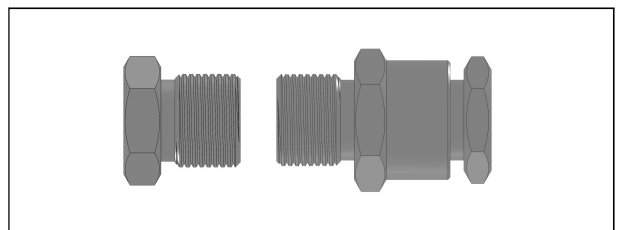

Product selection instruction

Transmission module

Code	Items	Description
F	Output signal	4-20mA two wire, power supply: 10.5-55VDC
H		4-20mA+HART two wire, power supply: 16.5-55VDC
R		Modbus-RTU/RS485, power supply: 5-32VDC
A	Display	Without display
C		With LCD display

Process connection selection

Code	Item	Description
H1	Flange/ Drain Valve	H structure, double flanges, process connection 1/4-18NPT(F), drain valve on the rear end of flange, material SS 316
H2		H structure, double flanges, process connection 1/4-18NPT(F), drain valve on the up part of flange, material SS 316
H3		H structure, double flanges, process connection 1/4-18NPT(F), drain valve on the down part of flange, material SS 316

Display module(C)

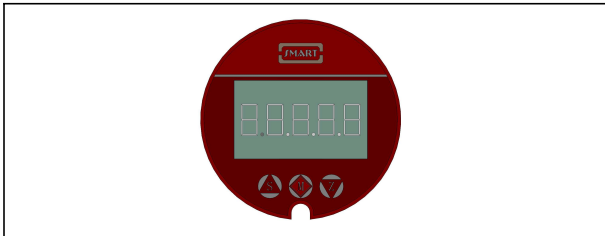

Terminals(N1)

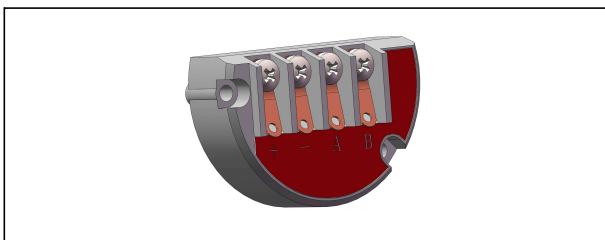

Flange

H1	
H2	
H3	

Wetted parts

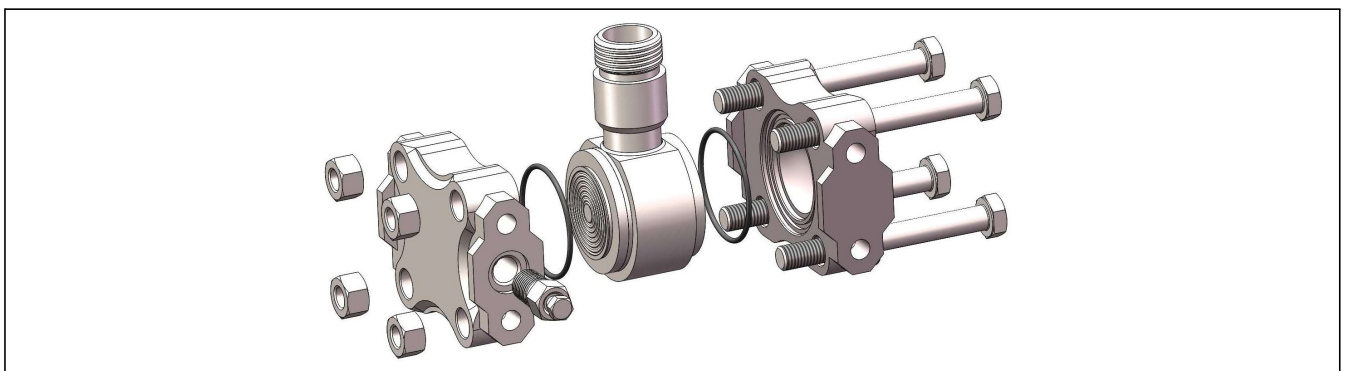

Disclaimer: all the data used in the product description is not legally binding. Relevant technical details may be changed due to further improve

**Product selection instruction**

**Process connection adaptor**

Code	Item	Description
A1	Process connection adaptor	Adaptor, M20*1.5 (M) with pressure-guided pipe $\Phi 14*2*30$ ,SS304, apply to H-structure
A2		Adaptor, 1/2-14NPT(F), SS 304, apply to H-structure

**Adaptor, M20\*1.5 (M) with pressure-guided pipe(A1)**

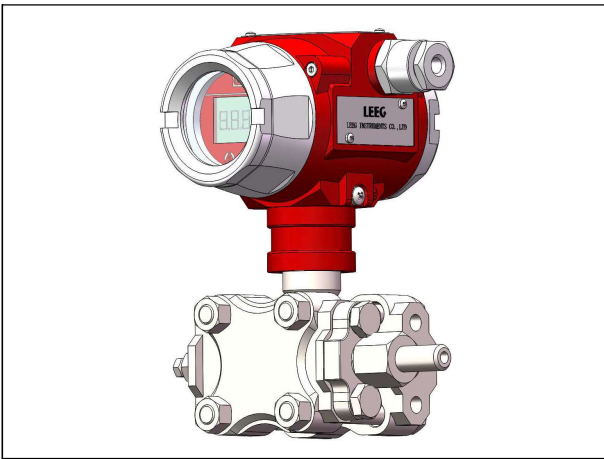

**Adaptor, 1/2-14NPT(F) (A2)**

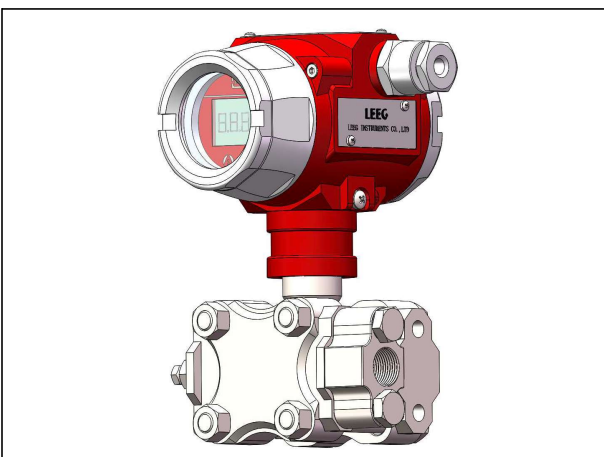

**Brackets**

Code	Items	Details
B1	Fixed mounting	Pipe mounting bent bracket,2" pipe, carbon steel, apply to H-structure
B2		Plate mounting bent bracket, carbon steel, apply to H-structure
B3		Pipe mounting flat bracket,2" pipe, carbon steel, apply to H-structure

**Pipe mounting bent bracket(B1)**

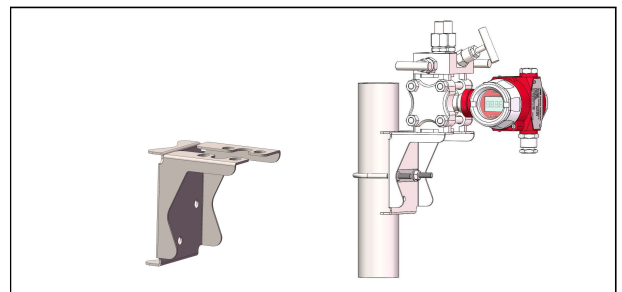

**Plate mounting bent bracket(B2)**

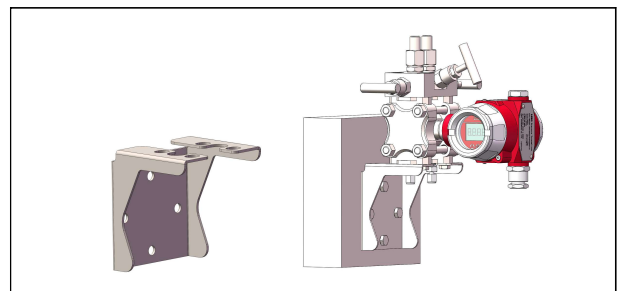

**Pipe mounting flat bracket(B3)**

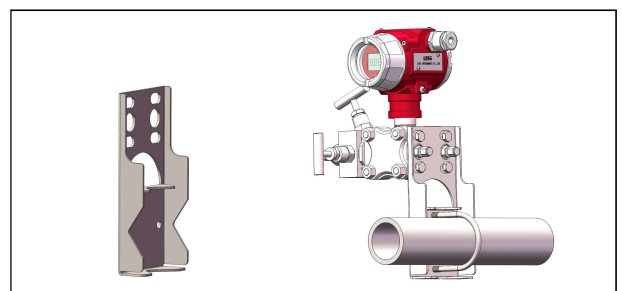

Product drawing and dimension

Drawing and dimension with display(C)(unit:mm)

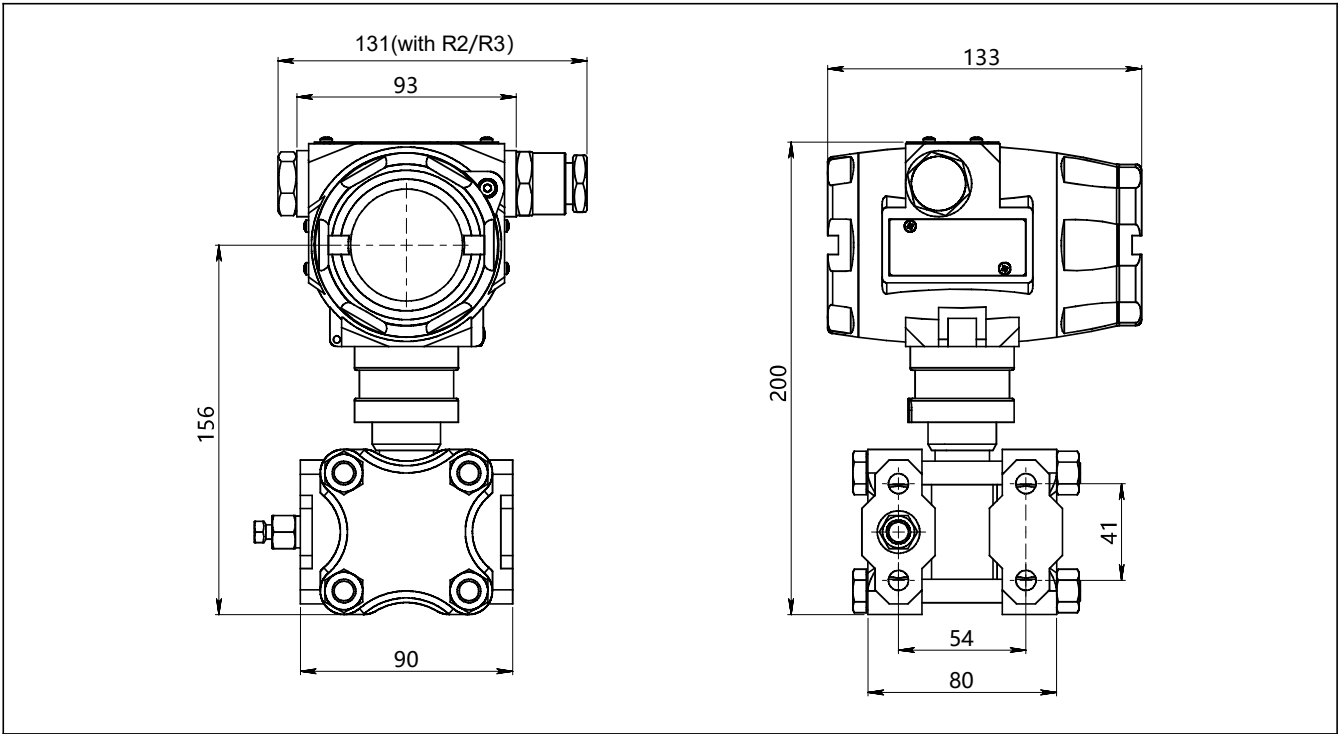

Drawing and dimension without display(A)(unit: mm)

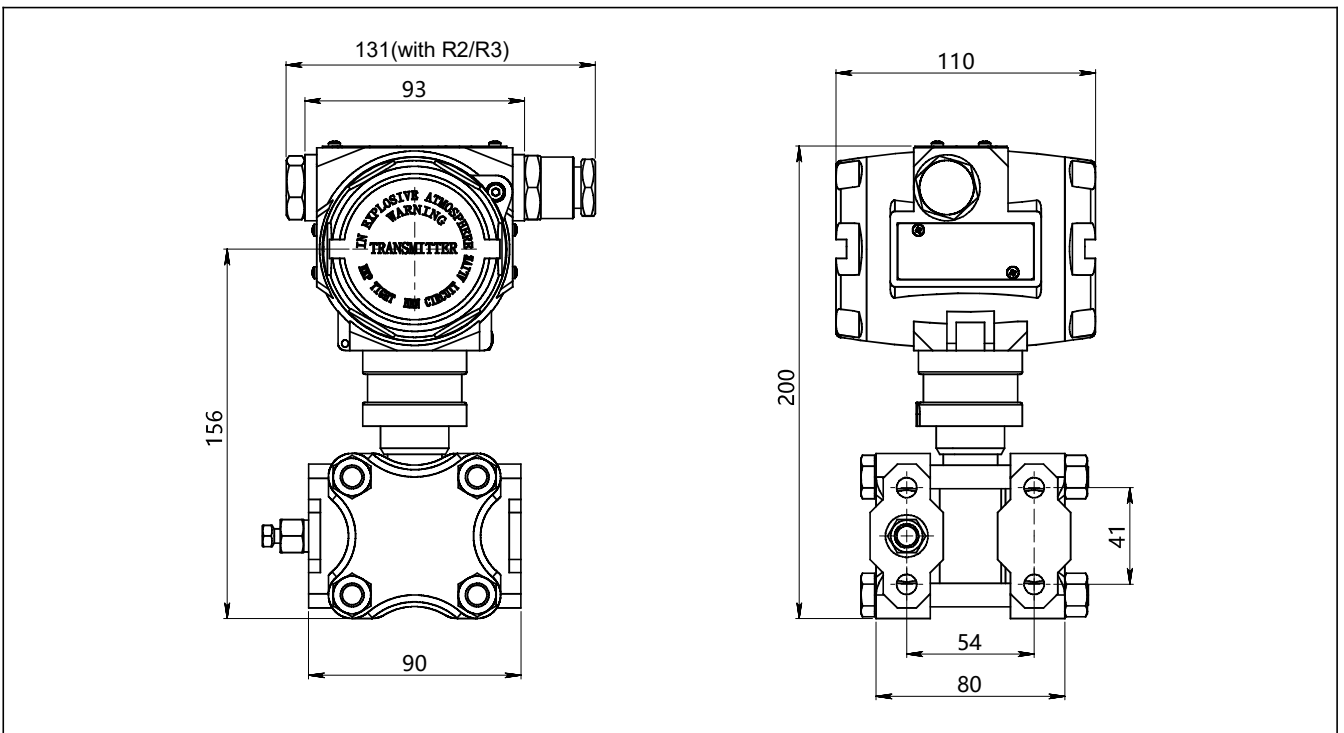

Disclaimer: all the data used in the product description is not legally binding. Relevant technical details may be changed due to further improve

Product drawing and dimension

Adaptor(A1) drawing and dimension(unit:mm)

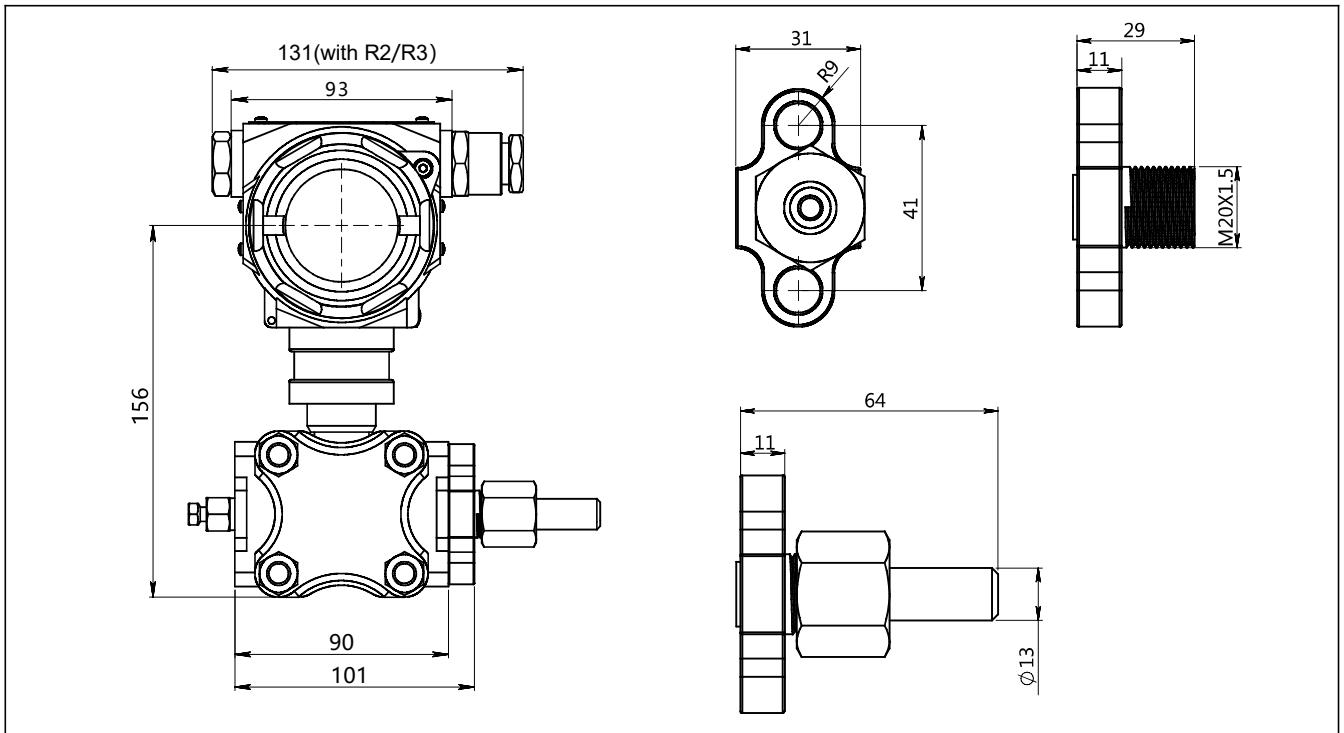

Adaptor(A2) drawing and dimension(unit:mm)

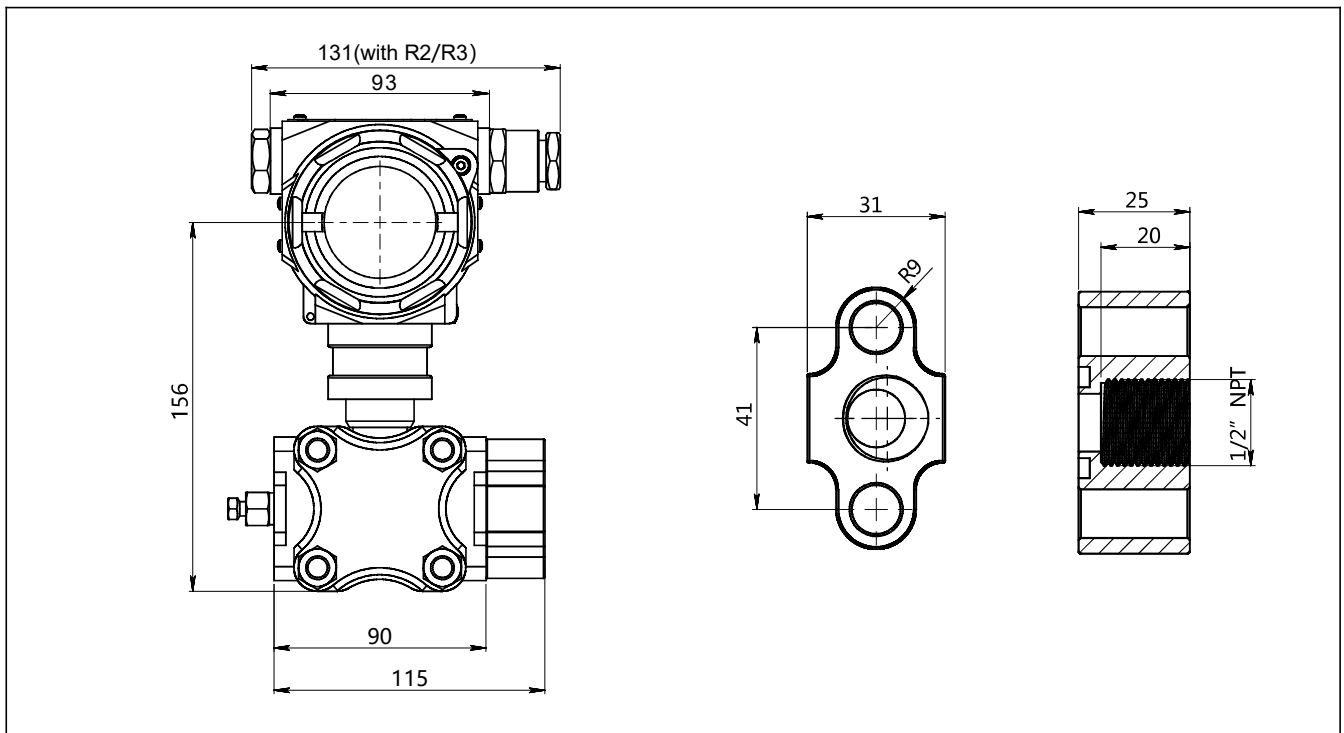

Disclaimer: all the data used in the product description is not legally binding. Relevant technical details may be changed due to further improve

Installation drawing and dimension

Pipe mounting bent bracket (B1) drawing and dimension (unit:mm)

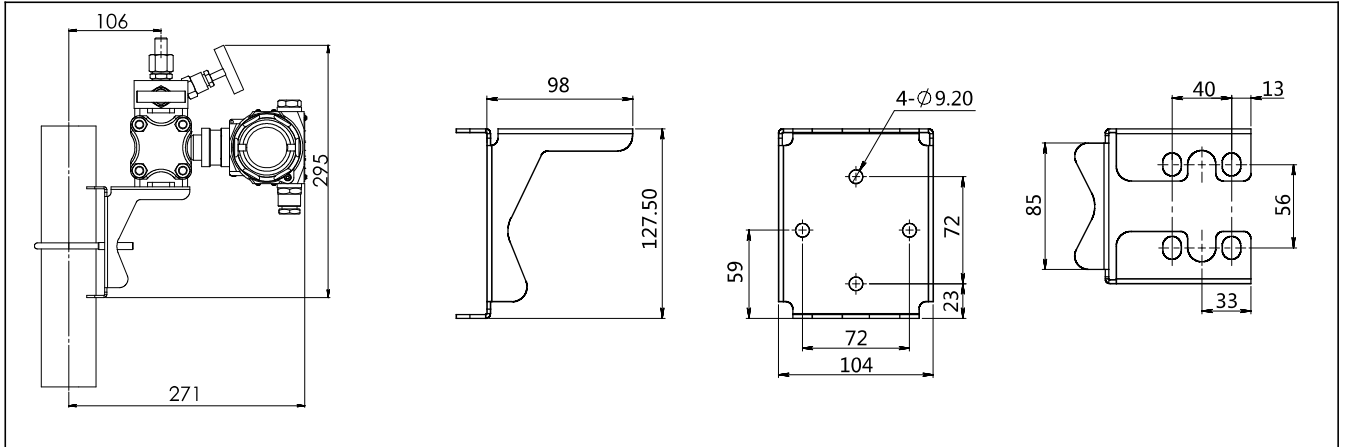
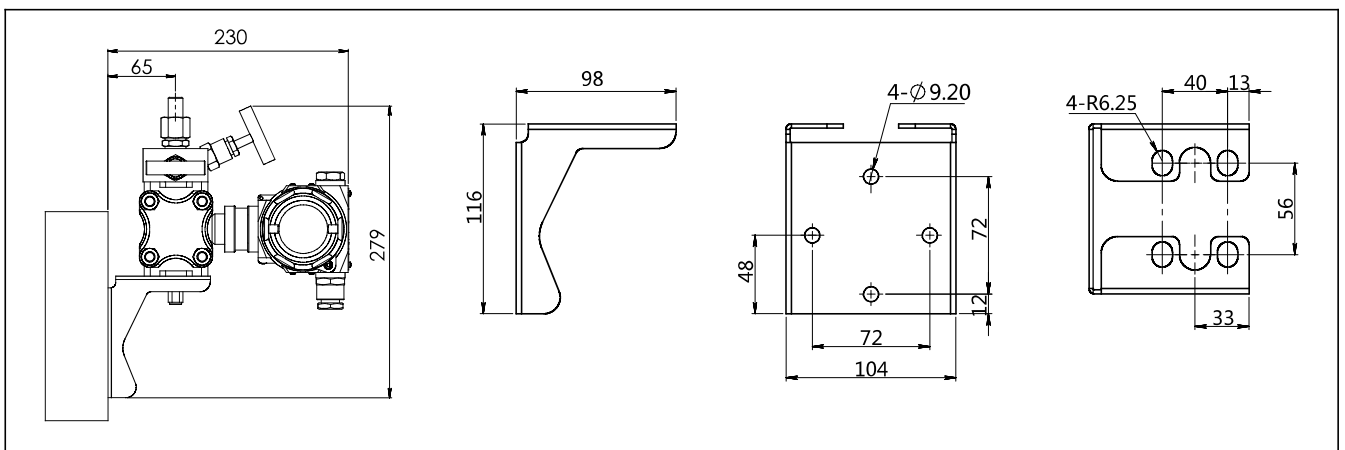
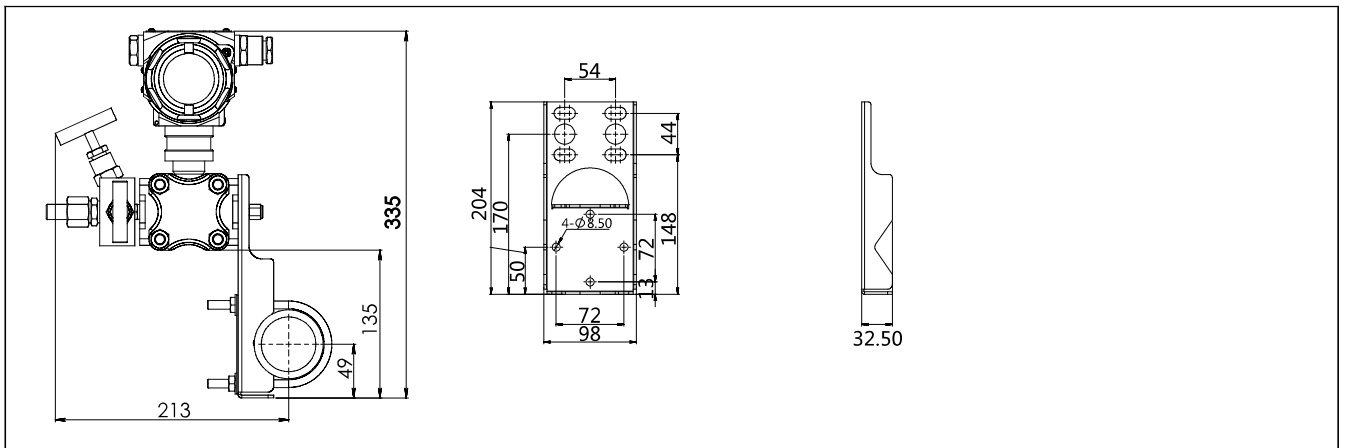

Plate mounting bent bracket(B2) drawing and dimension (unit:mm)



Pipe mounting flat bracket (B3) drawing and dimension (unit:mm)



Disclaimer: all the data used in the product description is not legally binding. Relevant technical details may be changed due to further improve

**Ordering information chapter**

Item	Parameters	Code	Instruction	(*) fast delivery available	
	Model	DMP305X-DST	Monosilicon absolute pressure transmitter		
Sensor	Separator	-	Detailed specifications as following		
	Pressure range code	S403A	Nominal value(URL): 40kPa(absolute)	*	
		S254A	Nominal value(URL): 250kPa(absolute)	*	
		S105A	Nominal value(URL): 1000kPa(absolute)		
		S106A	Nominal value(URL): 10MPa(absolute)		
	Diaphragm material	S	SUS316L		*
		H	Hastelloy C		
	Isolated filling fluid	S	Silicone oil, temperature resistance: -45-205°C		*
D		Inert oil, temperature resistance: -45-160°C			
Sensor seal	P	O-ring, PTFE, temperature resistance:-100-280°C			
Electrical connection	Separator	-	Detailed specifications as following		
	Electrical connection	T1	Aluminum-alloy terminal,2 cable entry M20*1.5(F), red body, white cover	*	
	Cable entry protector	R1	Waterproof connector M20X1.5 one side , blind plug another side, PVC material,6-8mm diameter cable only, IP66/IP67	*	
		R2	Flame proof, 1/2 NPT(F) one side, blind plug another side, stainless steel material, 6-8mm diameter cable only, IP66/IP67		
		R3	Flame proof, M20X1.5(F) one side, blind plug another side, stainless steel material, 6-8mm diameter cable only, IP66/IP67	*	
Output	Separator	-	Detailed specifications as following		
	Output signal	H	4-20mA+HART two wire, power supply:16.5-55VDC	*	
		F	4-20mA two wire, power supply: 10.5-55VDC		
	Display	C	LCD display	*	
		A	Without LCD display		
Process connection	Separator	-	Detailed specifications as following		
	Process connection	H1	H structure, double flanges, process connection 1/4-18NPT(F) ,drain valve on the rear end of flange, material SS 316	*	
		H2	H structure, double flanges, process connection 1/4-18NPT(F), drain valve on the up part of flange, material SS 316		
		H3	H structure, double flanges, process connection 1/4-18NPT(F),drain valve on the down part of flange, material SS 316		

Selection

Additional options	Separator	-	Detailed specifications as following	(*)fast delivery available
	Process connection accessory	/A1	Adaptor, M20*1.5 (M) with pressure-guided pipe Φ 14*2*30,SS304, apply to H-structure	*
		/A2	Adaptor, 1/2-14NPT(F), SS 304, apply to H-structure	
	Fix mounting accessory	/B1	Pipe mounting bent bracket, 2" pipe, carbon steel, apply to H-structure	
		/B2	Plate mounting bent bracket, carbon steel, apply to H-structure	
		/B3	Pipe mounting flat bracket, 2" pipe, carbon steel, apply to H-structure	*
	Calibration report	/Q1	Calibration report provide by our company	
		/Q2	Calibration report provide by chinese authorised third party	
		/Q3	Static pressure report ( Differential pressure only)	
	Approvals	/E1	Flame proof certificate NEPSI, ExdbIICT6 IECEEx or ATEX, Ex db IIC T6 Gb Ex tb IIIC T80°C CDb	1
		/I1	Intrinsic safety certificate IECEEx or ATEX, ExialICT4Ga NEPSI, ExialICT4	2
		/E2	Flame proof certificate, CSA Class I, Division 1, Group A, B, C and D T6 Class II, Division 1 Group E, F and G T80°C Class III	
		/F3	CE certificate	
	Wetted parts treatment	/G1	Ungrease treatment	
		/G2	Electropolishing treatment	

Note:

- 1 Please indicate ATEX or IECEEx or NEPSI when ordering
- 2 Please indicate ATEX or IECEEx or NEPSI when ordering

Factory settings and parameters

Item	Menu mark	Factory setting value
Tag position	None	0(No specific settings)
Analog output type	mA	Liner(No specific settings)
Display mode	DISP	PV(No specific settings)
Alarm signal	ALARM	No(No specific settings)

Item	Menu mark	Factory setting value
Damping value	DAMP	0(No specific settings)
4mA Lower range value	LRV	According to the order value
20mA Upper range value	URV	According to the order value
Process unit	U	According to the order

**Approvals**
**Factory certificate**

Certification organization	Intertek
Quality management system	ISO9001-2015
Scope of certification	Design and production of pressure transmitter
Registration number	110804039

**CE**

Certificate organization	ISET
License scope	DMP305X series pressure/differential pressure transmitter
Mark	EU
EMC instruction	2014/30/EU
Standard	AC/0100708
Registration number	IT41353LG161207

**Flame proof certificate**

Certificate organization	NEPSI	ATEX	IECEX	CSA
License scope	DMP305X pressure/differential pressure transmitter			
Explosion-proof mark	ExdIICT6	Ex db IIC T6 Gb, Ex tb IIIC T80°C Db		Class I, Division 1, Group A, B, C and D T6 Class II, Division 1 Group E, F and G T80°C Class III
Working temperature	-20°C to +55°C	-20°C to +60°C		-40-60°C
Maximum medium temperature	+80°C			
Registration number	GYB16.1254X	CML 19ATEX1078X	IECEX NEP 18.0008X	80020805

**Intrinsic safety certfite**

Certificate organization	NEPSI	ATEX	IECEX
License range	DMP305X series pressure/ differential pressure transmitter		
Explosion-proof mark	ExialICT4	Ex ia IIC T4 Ga	
Ambient temperature	-40°C to +60°C	-20°C to +60°C	
Medium maximum temperature	+120°C		
Registration number	GYB16.1962X	CML 19ATEX1078X	IECEX NEP 18.0008X
Intrinsically safe parameter description	Maximum input voltage:28VDC		Maximum input voltage:28VDC
	Maximum input current:100mA		Maximum input current:93mA
	Maximum input power:0.7w		Maximum input power:0.65w
	Maximum internal equivalent parameters Ci(uF):0		
	Maximum internal equivalent parameters Li(mH):0.01		Maximum internal equivalent parameters Li(mH):0

**Approvals**

**RoHS**

Certificate organization	ECM
License scope	DMP305X pressure/differential pressure transmitter
Mark	RoSH
Instruction	2011/65/EU
Certification criteria	IEC62321-1:2013 IEC62321-5:2014 IEC62321-2:2013 IEC62321-6:2015 IEC62321-4:2014 IEC62321-7-1:2015
Registration number	0H180504.SLIUQ03



scan & follow LEEG wechat



check website for more info