

Product introduction

Description



SMP131-TLD



SMP131-TLH

High performance pressure transmitter

SMP131 compact pressure transmitter combined with all the latest available technologies of the modern electronic pressure measurement fields. It's the most cost-effective products after 10 year's research and development. The sensor adopts full-automatic linear and temperature compensation technology to ensure the efficiency and quality of mass production. Fully-sealed and isolated air cavity design to ensure the long term reliability. Signal transmitting module adopts original calibration technology to realize parameters setting easily without any tools. SMP131 compact pressure transmitter has unique technological advantage which is different from other ordinary products with the same price and its' capabilities are equivalent to the most of the high-end products, which is the first selection of the most cost-effective products.

Main parameters

Pressure types	Absolute pressure
Measuring range	10kPa-3.5MPa, please refer to the ordering information chapter
Output signal	4-20mA, 4-20mA+HART, 0.5-4.5VDC Modbus-RTU/RS485, others
Reference accuracy	±0.2% URL, ±0.5% URL, optional ±0.1% URL

Field of application

Pressure and level measurement

Approvals

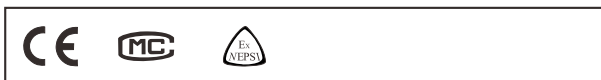

Measuring medium

The fluid which compatible with wetted parts

**Technical specifications**

**Measuring range and limit**

Nominal value	Smallest calibratable span	Lower range limit* ( LRL )	Upper range limit ( URL )	Overload limit
35kPa	10kPa	0kPa	35kPa	52.5kPa
100kPa	35kPa	0kPa	100kPa	150kPa
250kPa	100kPa	0kPa	250kPa	400kPa
400kPa	200kPa	0kPa	400kPa	600kPa
600kPa	300kPa	0kPa	600kPa	900kPa
1MPa	500kPa	0MPa	1MPa	1.5MPa
1.6MPa	1MPa	0MPa	1.6MPa	2.4MPa
3.5MPa	1.6MPa	0MPa	3.5MPa	5.25MPa

Above measurement range can be replaced by kg/cm<sup>2</sup>, MPa and kPa units .Which can provide other measurement range according to the requirements. Adjust requirements: lower range value (LRV) and upper range value (URV) can be adjusted within the scope of the upper and lower range limit, smallest calibratable span ≤ | URV-LRV | ≤ upper range limit

\*The actual lower range limit(LRL) is only approximately zero but can not reach absolute zero. Zero value can be calculated.

**Reference accuracy**

Including linearity, hysteresis and repeatability. calibration temperature: 20 °C ± 5 °C			
Linear output accuracy	Typical	±0.2%URL (HART output accuracy: ±0.1% URL)	Nominal value: 35kPa, 100kPa, 250kPa, 400kPa, 600kPa, 1MPa, 1.6MPa, 3.5MPa
	Max/Voltage output	±0.5% URL	

**Standard specifications and reference conditions**

Test standard: GB/T28474 / IEC60770; Zero based-calibration span, Linear output, Silicon oil filling, 316L stainless steel isolated diaphragm.

**Performance specifications**

The overall performance including but not limited to 【reference accuracy】 , 【environment temperature effects】 and other comprehensive error  
 Typical accuracy: ±0.2% URL (HART output accuracy: ±0.1% URL)  
 Stability: ±0.1% URL/ year

**Ambient temperature effects(Typical)**

Within the range - 20-80 °C total impact ±0.2%URL/10k

**Power supply effects**

Zero and span change should not be more than ± 0.005% URL/V

**Loading effects**

Zero and span change should not be more than ± 0.05% URL/kΩ

**Vibration effects**

Vibration resistance	According to IEC60068-2-6 , 10g RMS (25-2000HZ)
Impact resistance	According to IEC60068-2-27 , 500g/1ms

## Technical specifications

### Output signal

Signal	Type	Output
4-20mA	Linearity	Two wire
4-20mA+HART	Linearity	Two wire
0.5-4.5VDC	Linearity	Three wire
Modbus-RTU/RS485	Linearity	Four wire

### Working life

>10 million max pressure circulation

### Insulation resistance

≥ 20M Ω@, 100VDC

### Damping time

Total damping time constant: equal to the sum of damping time of amplifier and sensor capsule
Damping time of amplifier: 0-100S adjustable (with HART protocol)
Startup after power off: ≤3S (HART output time: ≤ 6S)
Normal services after data recovery: ≤4S (HART output time: 31S)

### Environment condition

Items	Operational condition
Working temperature	-40-85°C
Storage temperature	-40-100°C
Media temperature	-30-80°C
Working environment humidity	0-95%RH
Protection class	IP65
Dangerous condition	ExiaIICT4(GYB16.1964X)*
* Only for 4-20mA output	

## Technical Specifications

Signal output	4-20mA	4-20mA+HART*	0.5-4.5VDC	0.5-4.5VDC(ratiometric output)	RS485
Power supply voltage	10-30VDC	10.5/16.5-55VDC	6-30VDC	5VDC	5VDC/9-30VDC
Electric current	≤20.8mA		≤3.5mA		≤7mA
Load resistance(Ω)	<(U-10)/0.0208	<(U-10.5)/0.0208**	≥5k, recommend 100k		/
Transmission distance	<1000m		<5m		<1200m
Power consumption	≤500mW(20.8mA output@24VDC)		≤17.5mW(0.5-4.5VDCoutput, @5VDC)		≤168mW(RS485 output@24VDC)

\*For this output type, the load resistance value in communication is 250Ω

\*\*The load resistance value 0-2119Ω is in nominal working condition, 250-600Ω is HART communication

## Technical specifications

### EMC environment(not RS485 signal output)

NO.	Test items	Basic standards	Test conditions	Performance level
1	Radiated interference	GB/T 9254/CISPR22	30MHz-1000MHz	OK
2	Conducted interference (DC power port)	GB/T 9254/CISPR22	0.15MHz-30MHz	OK
3	Electrostatic discharge immunity test (ESD)	GB/T 17626.2/IEC61000-4-2	4kV(Contact ),8kV(Air)	B(Note2)
4	Immunity to radio frequency EM-fields	GB/T 17626.3/IEC61000-4-3	10V/m(80MHz-1GHz)	A(Note1)
5	Power frequency magnetic field Immunity test	GB/T 17626.8/IEC61000-4-8	30A/m	A(Note1)
6	Electrical fast transient / Burst Immunity Test	GB/T 17626.4/IEC61000-4-4	2kV(5/50ns,100kHz)	B(Note2)
7	Surge immunity requirements	GB/T 17626.5/IEC61000-4-5	1kV(Line to line) 2kV(Line to ground) (1.2us/50us)	B(Note2)
8	Immunity to conducted disturbances induced by radio frequency fields	GB/T 17626.6/IEC61000-4-6	3V(150kHz-80MHz)	A(Note1)

(Note 1)Performance level A: The performance within the limits of normal technical specifications.

(Note 2)Performance level B: Temporary reduction or loss of functionality or performance, it can restore itself. The actual operating conditions, storage and data will not be changed.

Product selection instruction

Sensor select instruction

Code	Nominal value	Description
L353A	35kPa	Range 0-35kPa, smallest calibratable span 10kPa
L104A	100kPa	Range 0-100kPa, smallest calibratable span 35kPa
L254A	200kPa	Range 0-200kPa, smallest calibratable span 100kPa
L404A	400kPa	Range 0-400kPa, smallest calibratable span 200kPa
L604A	600kPa	Range 0-600kPa, smallest calibratable span 300kPa
L105A	1MPa	Range 0-1MPa, smallest calibratable span 500kPa
L165A	1.6MPa	Range 0-1.6MPa, smallest calibratable span 1MPa
L355A	3.5MPa	Range 0-35MPa, smallest calibratable span 1.6MPa

Adjust requirements: lower range value (LRV) and upper range value (URV) can be adjusted within the scope of the upper and lower range limit, smallest calibratable span  $\leq |URV - LRV| \leq$  upper range limit

Code	Position	Description
S	Isolated diaphragm material	SUS316
S	Isolated filling fluid	Silicon oil, process temperature: -45-205°C
S	Sensor seal	O-ring, FKM, process temperature: -20-200°C
F		Stainless steel welding seal

Seal (S)



Electrical connection select instruction

Code	Description
D1	DIN43650, IP65
H1	Aviation plug, M12*1, 4 pin, IP67

DIN43650 ( D 1 )



DIN43650(D 1)

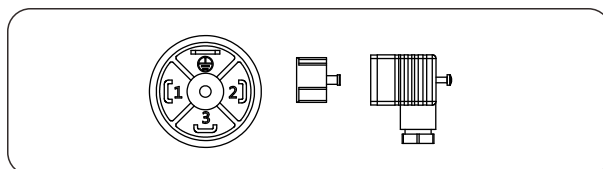

Label	Two wires	Three wires	Four wires	Modbus-RTU/RS485
1	Power+	Power+	Power+	Power+
2	Power-	Power-	Power-	Power-
3	Key-z	Signal+	Signal+	A+
⊕			Signal-	B-

Note: Key-z is modified zero pressure

Aviation plug, M12\*1(4 pin)(H1)



Aviation plug, M12\*1, 4 pin(H1)

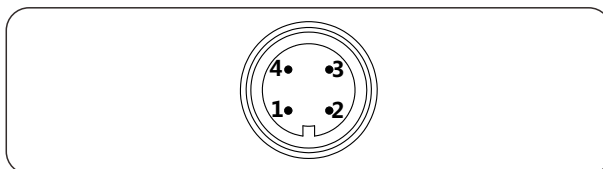

Label	Two wires	Three wires	Four wires	Modbus-RTU/RS485
1	Power+	Power+	Power+	Power+
2			Signal-	B-
3	Key-z	Signal+	Signal+	A+
4	Power-	Power-	Power-	Power-

Product selection instruction

Electrical connection accessory

Aviation plug straighter(J1)

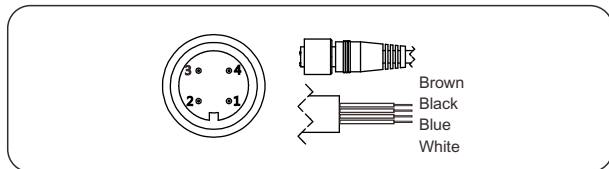

label	Two wires	Three wires	Four wires	Modbus-RTU/RS485
1/Brown	Power+	Power+	Power+	Power+
2/White			Signal-	B-
3/Blue	Key-z	Signal+	Signal+	A+
4/Black	Power-	Power-	Power-	Power-

Aviation plug elbow (J2)

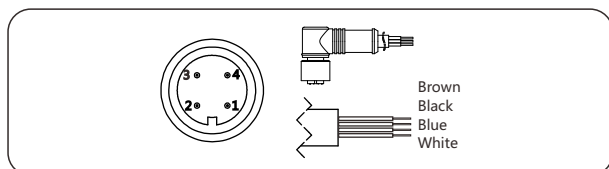

label	Two wires	Three wires	Four wires	Modbus-RTU/RS485
1/Brown	Power+	Power+	Power+	Power+
2/White			Signal-	B-
3/Blue	Key-z	Signal+	Signal+	A+
4/Black	Power-	Power-	Power-	Power-

Output signal select instruction

Code	Description
F	4-20mA two wire, power supply: 10-30VDC
H	4-20mA+ HART two wire, power supply: 16.5-55VDC
R	Modbus-RTU/RS485 5V/9-30VDC
5	0.5-4.5V DC three wire, power supply: 6-30VDC
6	0.5-4.5V DC three wire, ratiometric output, power supply: 5VDC
A	4-20mA two wire, Intrinsic safety, power supply: 10-30VDC

Wetted Parts

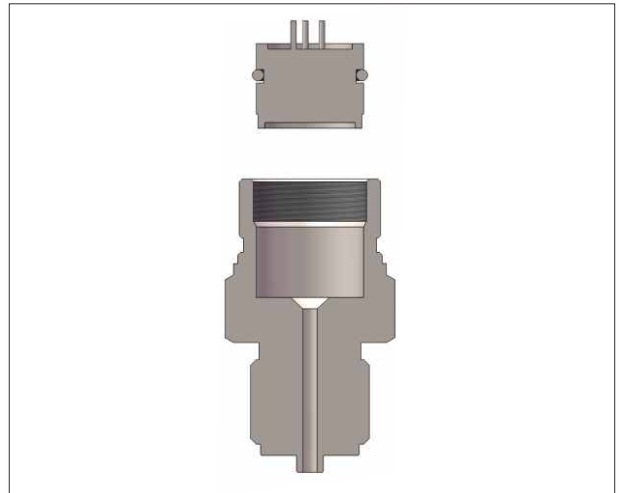

Process connection select instruction

Code	Type	Description
4	Material	SUS304
6		SUS316
M01	Specification	M20*1.5(M), Φ3 pressure lead hole, GB/T193-2003, ISO261
G01		G1/2(M), Φ3 pressure lead hole, EN837
G02		G1/4(M), Φ3 pressure lead hole, EN837
G08		G1/4(M), Φ3 pressure lead hole, GB/T7307, ISO228, DIN16288, BS2779, seal reference DIN3852-E ( back-end seal ) Max measuring range 60MPa
R01		1/2-14NPT(M), Φ3 pressure lead hole, GB/T12716, ANSI/ASME B1.20.1
R02		1/4-18NPT(M), Φ3 pressure lead hole, GB/T12716, ANSI/ASME B1.20.1
R03		1/2-14NPT(F), Φ3 pressure lead hole, GB/T12716, ANSI/ASME B1.20.1
R04		1/4-18NPT(F), Φ3 pressure lead hole GB/T12716, ANSI/ASME B1.20.1

Product drawing and dimension

Drawing and dimension with DIN43650(D1) (unit: mm)

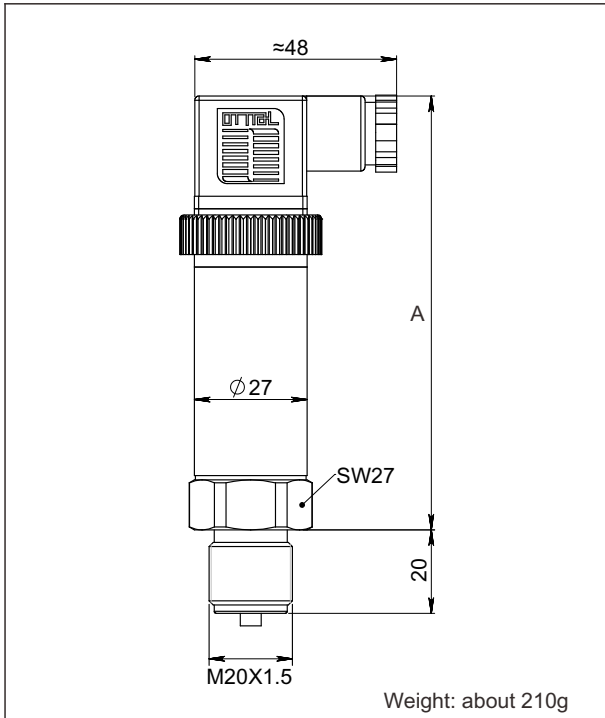

Value of A in different output signal types(DIN43650 adaptor)

Output signal code	(Accuracy $\leq$ 0.1% URL)	Other accuracy
F, H, A	123	108
5, 6	-	108
R	123	123

Drawing and dimension with aviation plug(H1) (unit: mm)

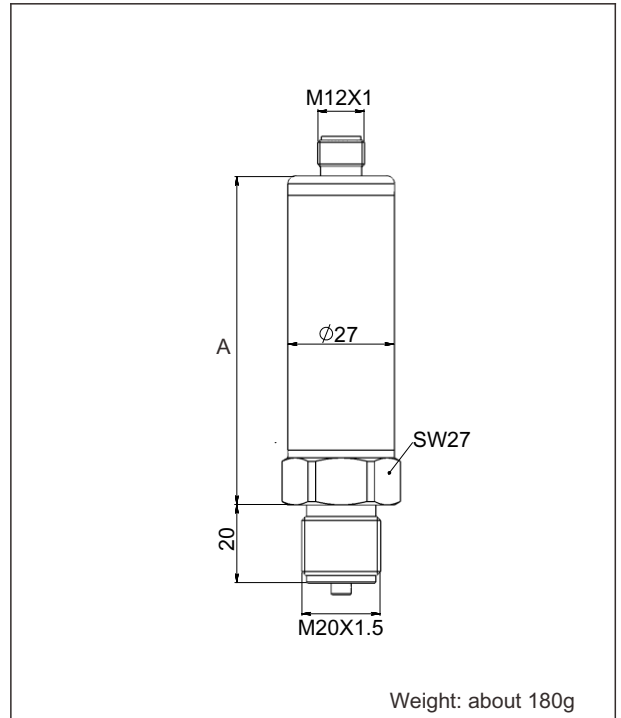

Value of A in different output signal types(Aviation plug)

Output signal code	(Accuracy $\leq$ 0.1% URL)	Other accuracy
F, H, A	83	68
5, 6	-	68
R	83	83

Process connection(M01) (unit: mm)

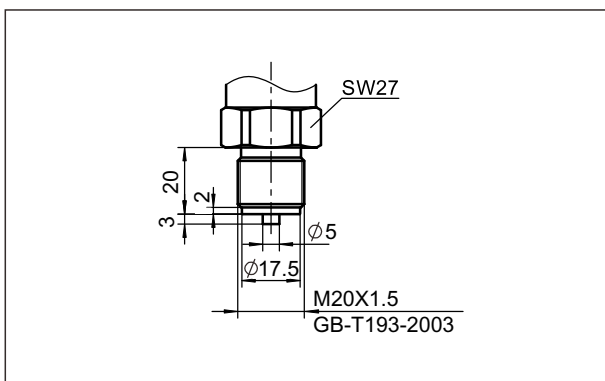

Process connection(G01) (unit: mm)

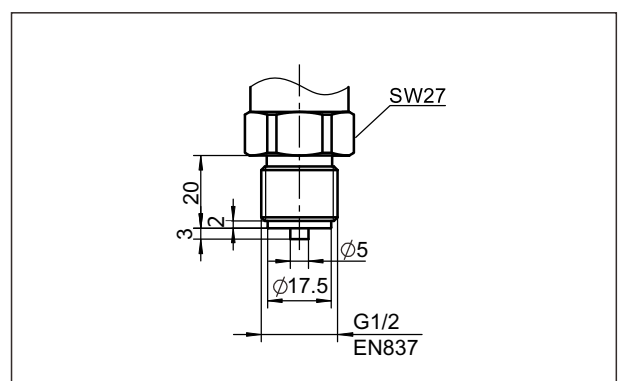

Product drawing and dimension

Process connection(G02) (unit: mm)

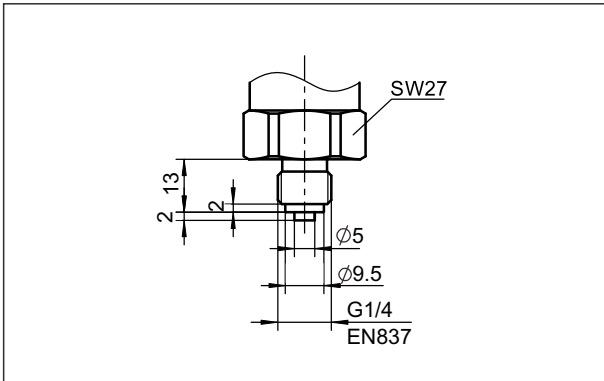

Process connection(G08) (unit: mm)

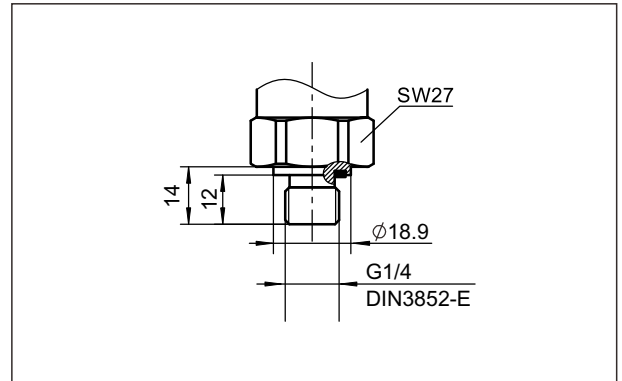

Process connection(R01) (unit: mm)

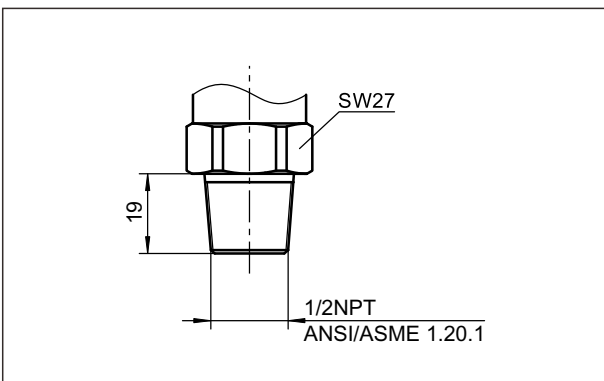

Process connection(R02) (unit: mm)

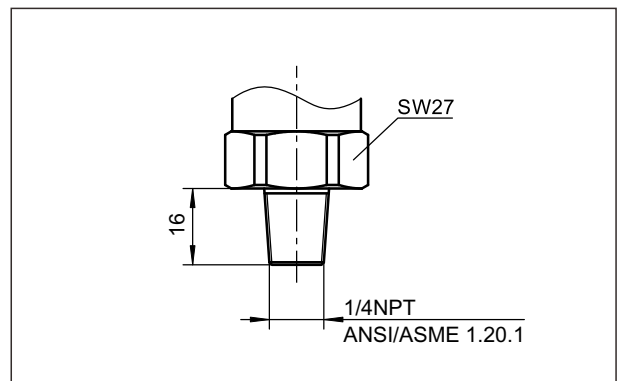

Process connection(R03) (unit: mm)

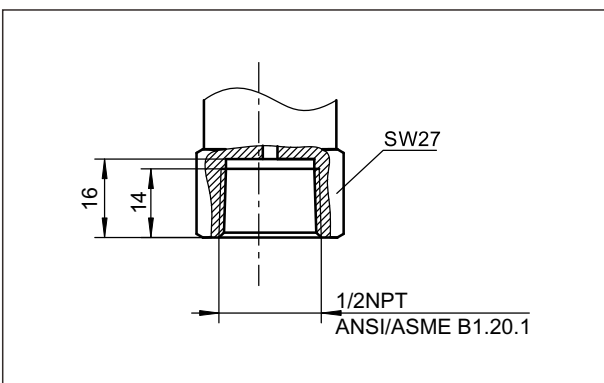

Process connection(R04) (unit: mm)

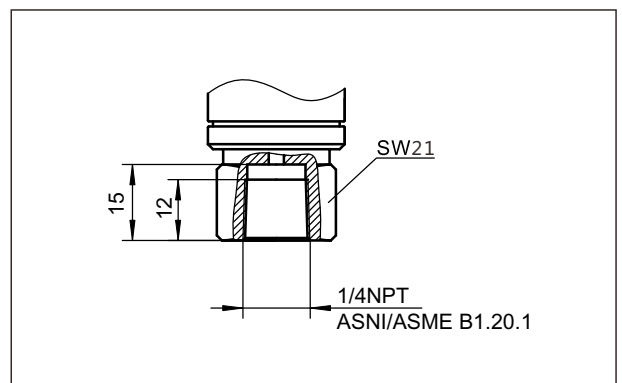

Product drawing and dimension

Heat exchange connector(N1) (unit: mm)

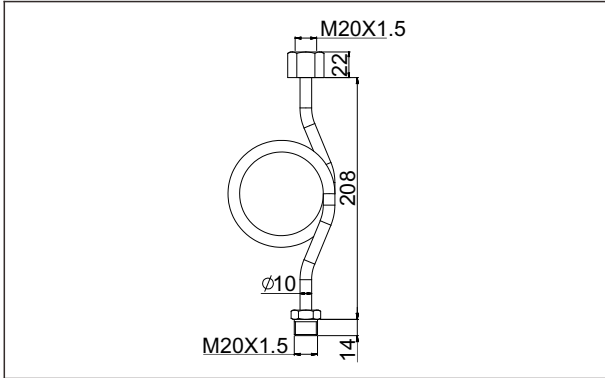

Heat exchange connector(N2)(unit: mm)

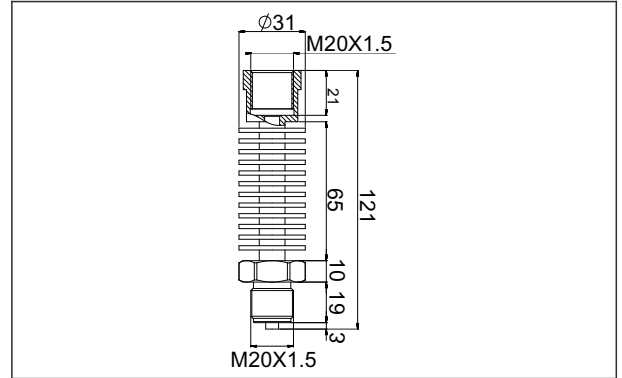

Welding adaptor(Z1) (unit: mm)

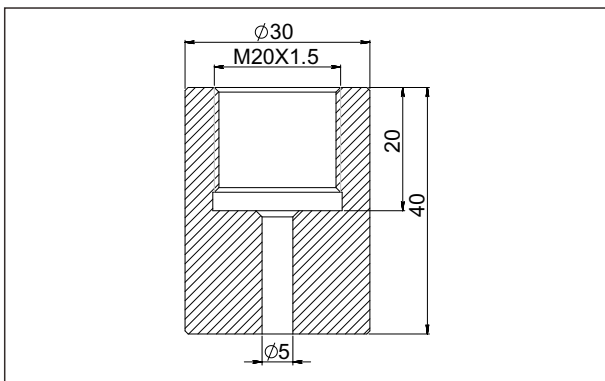

Welding adaptor(Z2) (unit: mm)

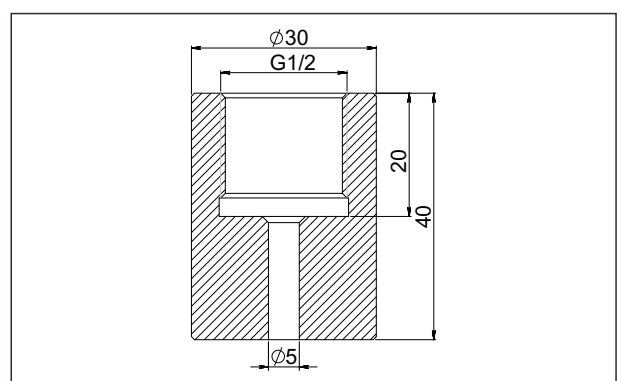

Aviation female plug straighter(J1) (unit: mm)

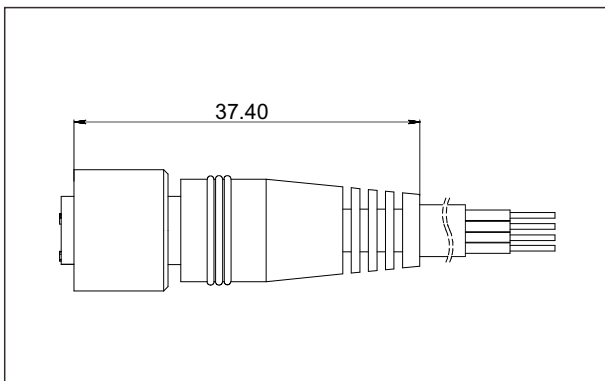

Aviation female plug elbow(J2) (unit: mm)

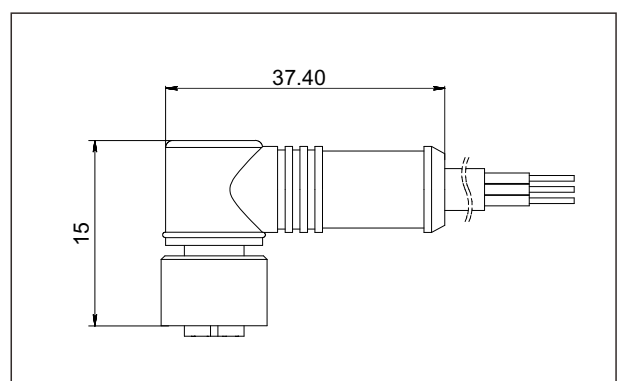

**Ordering information chapter**

Item	Parameters	Code	Instruction	(*) fast delivery available
	Model	SMP131-TLD	Piezoresistive silicon absolute pressure transmitter (The first letter of electrical connection type is D)	*
		SMP131-TLH	Piezoresistive silicon absolute pressure transmitter (The first letter of electrical connection type is H)	*
Sensor	Separator	-	Detailed specifications as following	
	Pressure range code	L353A	Nominal value(URL): 35kPa	*
		L104A	Nominal value(URL): 100kPa	*
		L254A	Nominal value(URL): 250kPa	*
		L404A	Nominal value(URL): 400kPa	*
		L604A	Nominal value(URL): 600kPa	*
		L105A	Nominal value(URL): 1000kPa	*
		L165A	Nominal value(URL): 1.6MPa	*
		L355A	Nominal value(URL): 3.5MPa	
	Isolated diaphragm material	S	SUS316	*
	Isolated filling fluid	S	Silicon oil filling, process temperature: -45-205°C	*
Sensor seal	S	O-ring, FKM, process temperature: -20~200°C	*	
	F	Stainless steel welding		
Electrical connection	Separator	-	Detailed specifications as following	
	Electrical connection	D1	DIN43650, IP65	*
		H1	Aviation plug, M12*1(4pin), IP67	*
	Cable entry protector	R0	None	
Output	Separator	-	Detailed specifications as following	
	Output signal	F	4-20mA two wire, power supply: 10-30VDC	*
		H	4-20mA+HART two wire, power supply: 16.5-55VDC	
		R	Modbus-RTU/RS485 four wire, power supply:5vdc/9-30VDC	
		5	0.5-4.5VDC three wire, power supply: 6-15VDC	
		6	0.5-4.5VDC three wire, ratiometric output, power supply: 5VDC	
		A	4-20mA two wire, intrinsic safety, power supply: 10-30VDC	
Body tube	Separator	-	Detailed specifications as following	
	Tube	53	Stainless steel tube length: 53mm (HART、Modbus-RTU/RS485 is not available)	*
		37	Stainless steel tube length: 37mm (HART、Modbus-RTU/RS485 is not available)	
		65	Stainless steel tube length: 65mm (with HART、Modbus-RTU/RS485, accuracy≤0.1%)	
		85	Stainless steel tube length: 85mm (with HART、Modbus-RTU/RS485, accuracy≤0.1%)	

Disclaimer: all the data used in the product description is not legally binding. Relevant technical details may be changed due to further improve

**Ordering information chapter**

Process connection	Separator	-	Detailed specifications as following	
	Material	4	SUS304	*
		6	SUS316	
	Specification	M01	M20*1.5 (M), Φ3 pressure lead hole, GB/T193-2003, ISO261	*
		G01	G1/2 (M), Φ3 pressure lead hole, EN837	*
		G02	G1/4(M), Φ3 pressure lead hole, EN837	
		G08	G1/4(M), Φ3 pressure lead hole, GB/T7307, ISO228, DIN16288, BS2779, seal refers to DIN3852-E (back-end seal), maximum measuring range: 60 MPa	
		R01	1/2 -14NPT(M), Φ3 pressure lead hole, GB/T12716, ANSI/ASME B1.20.1	
		R02	1/4 -18NPT(M), Φ3 pressure lead hole, GB/T12716, ANSI/ASME B1.20.1	
		R03	1/2 -14NPT(F), Φ3 pressure lead hole, GB/T12716, ANSI/ASME B1.20.1	
R04	1/4 -18NPT(F), Φ3 pressure lead hole, GB/T12716, ANSI/ASME B1.20.1			
Additional options	Separator	-	Detailed specifications as following	
Process connection mounting accessory	/N1		Heat exchange connector, M20*1.5 (F) change to M20*1.5(M), SUS304 (Condenser pipe)	*
			Heat exchange connector, M20*1.5 (F) change to M20*1.5(M), SUS304 (Cooling fin)	*
Process connection accessory	/Z1		Welding adaptor, M20*1.5(F), SUS304	*
	/Z2		Welding adaptor, G1/2(F), SUS304	*
Electrical connection accessory	/J1		Aviation female plug (straighter) with 2m cable, 4 pin, M12*1, IP67	*
	/J2		Aviation female plug (elbow) with 2m cable, 4 pin, M12*1, IP67	
	/J4		Aviation female plug (straighter) without cable, 4 pin, M12*1, IP67	*
	/J5		Aviation female plug (elbow) without cable, 4 pin, M12*1, IP67	
Approvals (multiple)	/I1		Intrinsic safety certificate, ExialICT4, NEPSI	
	/F3		CE certificate	
Wetted parts treatment	/G1		Ungrease treatment	
	/G2		Electropolishing treatment	

**Approvals**

**Factory certificate**

Certification organization	Intertek
Quality management system	ISO9001-2008
Scope of certification	Design and production of pressure transmitter
Registration number	110804039

**CE**

Certificate organization	ISET
License scope	SMP131 series pressure transmitter
Mark	EU
EMC instruction	2014/30/EU
Standard	AC/0100708
Registration number	IT031353LG161207

**Intrinsic safety certificate**

Certification organization name	NEPSI
License range	SMP131 series pressure transmitter
Explosion-proof mark	ExialICT4
Ambient temperature	-40-+60°C
Medium maximum temperature	+120°C
Registration number	GYB16.1964X
Intrinsically safe parameter description	Maximum input voltage: 28VDC
	Maximum input current: 100mA
	Maximum input power: 0.7w
	Maximum internal equivalent parametersCi(uF): 0
	Maximum internal equivalent parametersLi(mH): 0



scan & follow LEEG wechat



check website for more info